

# **TDP/NJI FlashMaster**

## **Grade crossing Flasher controller**

You have purchased the TDP FlashMaster. The FlashMaster is a prototypical grade flasher controller for your model railroad. The basic kit controls a single track grade crossing. By adding a second sensor cable the FlashMaster will operate a two track grade crossing bidirectionally. To expand beyond two bidirectional tracks additional FlashMaster boards are needed, one board per two additional tracks (as with the basic kit an additional sensor cable is needed for the second track per FlashMaster board).

The FlashMaster uses optical sensors (three per track) to detect the train. These sensors require visible room lighting to function. The FlashMaster IR uses IR reflective sensors to detect the trains and will work without room lighting. The FlashMaster also provides a control output to operate a grade crossing bell unit.

### **Contents of the Kit**

- FlashMaster Board
- Sensor cable (Optical or IR)
- Output cable
- Optional additional sensor cable (for second track, purchased separately)

### **Power Requirements**

The FlashMaster requires a power supply of 8V – 18V AC or DC capable of supplying 300 ma (the auxiliary terminals of your power pack or a wall transformer will work).

### **Precautions**

Care must be taken to ensure that you do not short out the FlashMaster board or the sensors during installation. Do not place the circuit board on the rails when you are working on it, and make sure that the rails are not powered when installing the sensors. Touching a sensor or the FlashMaster board to a powered rail will probably damage the sensor and/or the FlashMaster board.

# FlashMaster Board

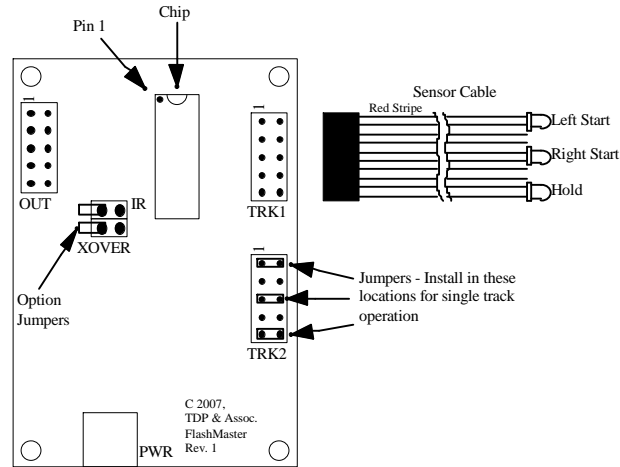

Figure 1

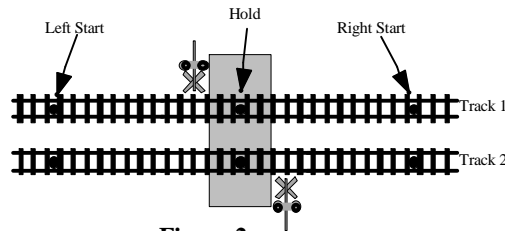

Figure 2

## Installation

The installation of the FlashMaster is quite easy. Each track will receive three sensors. There is a 'left' start sensor, a 'right' start sensor and a 'hold' sensor (see figure 1). On the grey cable the sensor closest to the red stripe is the 'left' start sensor. The middle sensor is the 'right' start sensor, and the sensor farthest away from the red stripe is the 'hold' sensor. Figure 2 shows the location of the sensors in the tracks. The 'hold' sensor should be placed at the road, ideally right between the flashers, though if it is offset to one side of the road it will still work. The start sensors should be placed on either side of the grade crossing a sufficient distance away from the crossing to provide adequate warning. To install an optical sensor drill a #19 or #20 hole along the centerline of your track between two ties. IR sensors require larger holes (about 5/16" or 8mm) which will require the removal of at least one tie in N and HO scales. You then insert the sensor from below and push it up until the top of the sensor is even with the top of the ties. If you are doing a multitrack installation make sure that all the sensors from one cable are installed on the same track. You must install all three sensors even if your tracks are single directional! If the light is coming in at an angle (if your lighting is not directly over the track) you may need to angle the holes such that the sensors are 'aimed' at the light source. If the light source is in the isles you may encounter false triggering when someone walks by and casts a shadow on the track.

Once the sensors are installed you can wire up the lights from the flashers. The FlashMaster board was designed to operate with LED crossing lights. Ideally the flashers should be wired up as 'common anode' (NJI and Walther's flashers are wired this way). Each flasher should have three wires. A common wire (the positive lead) and two light wires. Wiring diagrams are given on page 9. If your flashers already have resistors installed in the wires you should connect the common wires to the output cable's wire #5.

**Wire #1 is the wire with the red stripe.** NJI flashers usually come prewired with resistors. If your flashers do not have resistors already installed, or you are unsure if they have resistors, connect the common wire to wire #4 of the output cable. Wire #4 has a resistor already installed on the FlashMaster board for use with crossing lights that do not have their own resistors. The Walther's flashers do not have resistors. Connect one light wire from each flasher to wire #1 of the output cable and the other light wires from each flasher to wire #2 of the output cable. Depending upon the resistor size four to six sets of LED flashers can be powered from one FlashMaster. If the LEDs are not bright enough when you use wire #4 you will need to use wire #5 and provide your own resistors (use one for each set of crossing lights). Flasher wiring diagrams are given on page 9.

Connect the sensor cable to the TRK1 connector on the FlashMaster board (see figure 1). The red stripe on the cable should be installed towards the '1' on the FlashMaster board. If you are installing a single track grade crossing with optical sensors be sure to install the three jumpers shown in Figure 1 (these will come installed from the factory). If you are using the IR sensors these jumpers should be removed. If you are installing a two track crossing remove the jumpers and install the track 2 sensor cable on the TRK2 connector on the FlashMaster board, again orienting the red stripe towards the '1' by the connector. Install the output cable on the OUT connector on the FlashMaster board, again orienting the red stripe towards the '1' beside the OUT connector (see figure 1).

If you are using IR sensors check to make sure that the option jumper marked 'IR' (see figure 1) is installed across both posts. For optical sensors this jumper should be installed over only one post (or it can be removed completely).

You can now connect the power supply to the board using the two screw terminals labeled 'PWR' on the FlashMaster board (see figure 1).

When you apply the power to the FlashMaster and the sensors are correctly installed and all have sufficient light shining on them (in the case of the IR sensors no light is required) the flashers should remain off until one of the sensors is covered by something (a train or a finger).

## Operation

The FlashMaster was designed to operate prototypically, without requiring any connections to the track power to determine which direction the train is traveling. The sequence runs in four phases. The first phase is when any start sensor is triggered. This will turn on the lights. The FlashMaster will then wait until it sees that the hold sensor is covered **AND** the start sensor that started the sequence is uncovered. This is the second phase. The system now waits for the hold sensor to be uncovered. Six flashes after the hold sensor is uncovered the lights will go out and phase three starts. In phase 3 the FlashMaster will wait until it sees the opposite start sensor is covered (that is the sensor that did **not** start the sequence). Phase 4 then begins, where the FlashMaster will wait until the opposite start sensor is uncovered for 3 seconds. This ensures that if the sensor 'sees' light as the gap between the cars passes over it, it will not incorrectly trigger another grade crossing sequence. After phase 4 completes the FlashMaster is ready to start another grade crossing sequence. In the case of a two track installation, the sequences for each track are monitored independently, such that the lights will be on for as long as necessary for the trains on both tracks to clear the crossing.

The system has a two minute timeout built into it. This timeout will end a crossing sequence if none of the sensors are covered for two minutes. This feature was added to allow the FlashMaster to recover from a false trigger event like when a person accidentally covers one sensor while they are working around the railroad.

## Advanced Operational Options

The FlashMaster has an advanced operational mode that will take care of a crossing that is located where two tracks merge into one (like at the end of a passing siding), or a crossover is located within the crossing area. This mode is selected by installing the jumper labeled 'XOVER' across both posts in the case of the two to one track option. In the case of a crossover Pins 6 & 10 of the OUT cable can be wired to a set of contacts on one of the switch machines being used to control the crossover. The two wires should be hooked to a set of contacts that will be shorted when the crossover is set to crossover. When the 'XOVER' jumper is shorted by either a jumper or the contacts of a switch machine the sequence will end when either opposite start sensor is covered. For example, if the track 1 left start sensor has started the crossing sequence and the train is crossing over to track 2, the sequence would not be completed if the FlashMaster is working in the normal mode because the track 1 right start sensor would not be covered as the train exits the crossing area. So, this 'XOVER' mode will allow the track 2 right start sensor to complete the sequence. Figure 3 shows the track/sensor configurations supported. In the case of the one track to two tracks there will be one unused start sensor. If that sensor is an optical sensor it needs to be cut off the cable and the two wires shorted together for the system to operate correctly. In the case of the IR sensors all that is needed is to cut the sensor off the cable. When a crossover is involved, by using the contacts on the switch machine the crossing operation will be correct for all possibilities. If you choose to just use the jumper some false triggering may occur when two trains are using the crossing at the same time when the crossover is not thrown.

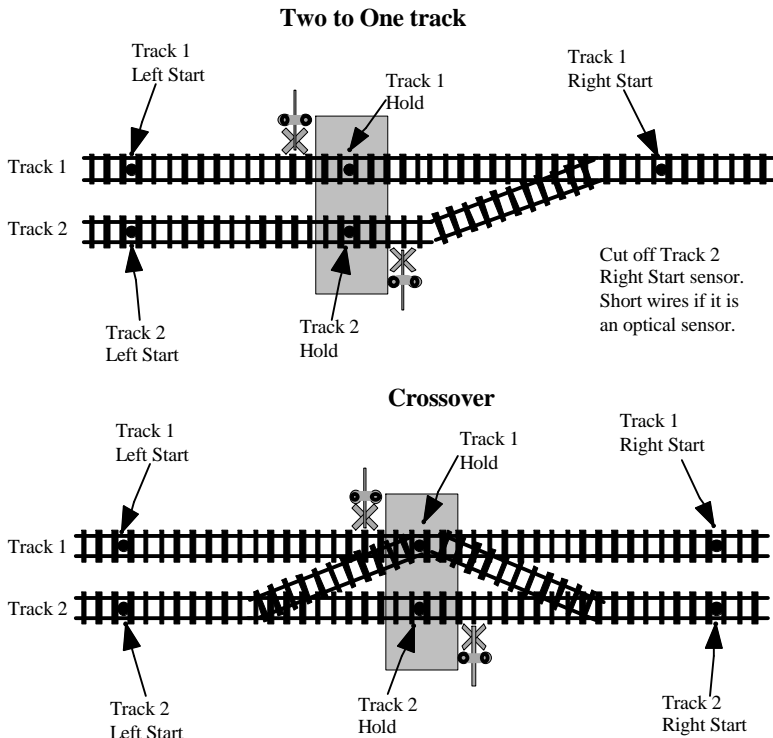

**Figure 3**

In the case of the two to one track setup, even if the road is located in the single track segment, **both** hold sensors **must** be used. Also, in this advanced mode you must make sure that both track's 'left' sensors **MUST** go to the same side of the crossing. If they do not the crossing logic will not function properly.

## IR Sensors

The IR reflective sensors will allow operation in the dark, but they do have limitations. The biggest problem with them is they have a hard time 'seeing' black bottomed tank cars. They also have a limited range of detection, so they may also have trouble with the larger scales. They will most likely detect the trains correctly to start the sequence, but the lights may turn off prematurely if there is a string of black bottomed tank cars in the train. Remember, the lights will go out when the hold sensor is uncovered for six flashes (about 6 seconds). That time interval is long enough that in most cases the lights won't be incorrectly shut off, but since the time needed to complete the cycle is only three seconds (when the opposite start sensor is uncovered as a train leaves the crossing area), the lights may be incorrectly retriggered by a car that the sensor cannot 'see'. If this occurs the FlashMaster will timeout after about 2 minutes and the lights will go out again.

The IR sensors may trigger if there is a sudden change in ambient lighting. This condition will correct itself once the crossing is left idle for the two minute timeout period. If a train enters the crossing area during this period the operation of the lights may not sequence correctly. As soon as the crossing area has been left idle for the two minute timeout period the crossing will operate correctly.

## Other Detection Options

Other commercially available detectors can be used with the FlashMaster. Specifically, if a detector provides a 'high' (voltage greater than 1.5V and no greater than 5.0V) for a detected block then the sensors can be cut off and the wires connected to the third party detector. See the connector pinout tables at the end of this manual for the cable pin assignments. If the third party detector provides a 'low' (voltage less than 0.8V) then the signal will need to be inverted to work correctly. Note that you will need three distinct 'blocks' on each track to make the FlashMaster work correctly. The block to the left of the crossing, the block to the right of the crossing and a short 'hold' block located right at the crossing.

## Cascade Operation (more than 2 tracks)

When using more than two tracks an additional FlashMaster board is required. The lights will only be connected to one of the boards, which we will call the master board. The second FlashMaster, which we will call the slave board, is being used only for detection logic. To cascade the two boards together you need to connect pin 7 of the master board's output cable to pin 8 of the slave board's output cable and connect pin 6 of the master board's output cable to pin 6 of the slave board's output cable. The rest of the

installation of the slave board should follow the standard instructions for the placement and connection of the sensors.

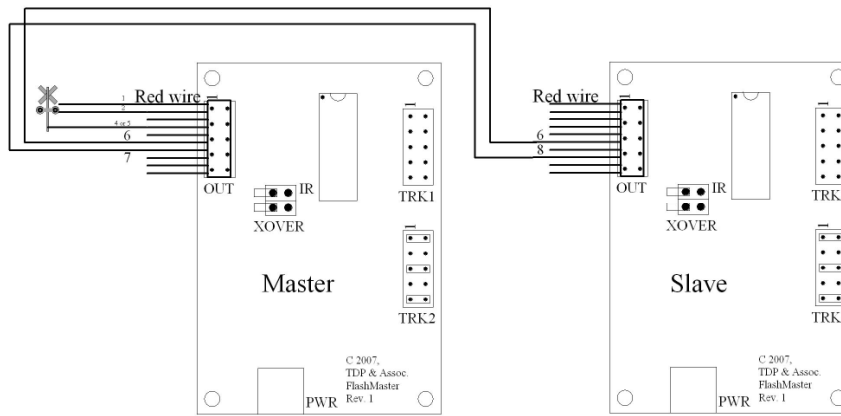

The cascade input can also be used as a manual override to allow a crew to turn on the lights when they are working within the grade crossing's sensors. All you need to do is connect a toggle switch between the output cables wires 6 & 7.

## Pin Assignments for Provided Cables

The output cable, which is connected to the 'OUT' connector boards interfaces to the lights, an optional bell unit and an additional FlashMaster board when three and four tracks are desired.

Output Cable

Pin #	Signal	Description
1	Light 1	Connect to one of the two light wires from the flashers
2	Light 2	Connect to the other light wire from the flashers
3	+5V	Available for incandescent lights
4	COM_RES	Connect to the common wire from the flashers if your flashers do not have resistors installed
5	COM	Connect to the common wire from the flashers if your flashers have resistors installed
6	GND	GND (0V) connection
7	Cascade	Input to master unit when cascading two units together for more than two track operation
8	BELL_neg	External bell unit trigger – low going signal
9	BELL_pos	External bell unit trigger – high going signal
10	XOVER	Crossover input (see advanced options)

Table 1

The sensor cable connections are provided if you wish to use third party detection.

Sensor cable

Pin #	Signal	Description
1	Left_start	Left start sensor logic input (do not exceed 5V!)
2	GND	GND (0V)
3	Left_flash	IR sensor connection to the IR source for the left sensor
4	+5V	+5V
5	Right_start	Right start sensor logic input (do not exceed 5V!)
6	GND	GND (0V)
7	Right_flash	IR sensor connection to the IR source for the right sensor
8	Hold_flash	IR sensor connection to the IR source for the hold sensor
9	GND	GND (0V)
10	Hold	Hold sensor logic input

Table 2

# Light wiring options

**Common Anode w/common external resistor**

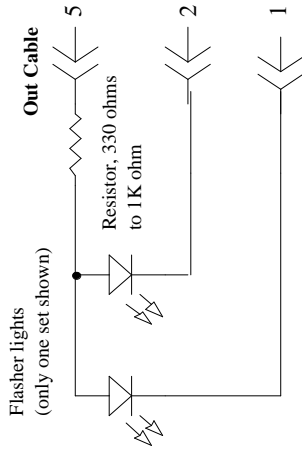

**Common Anode without external resistors**

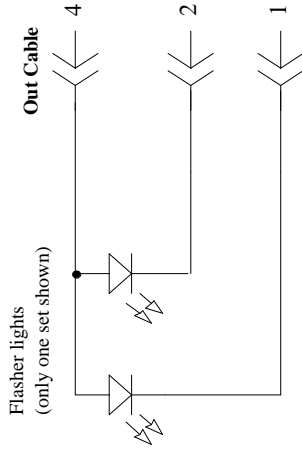

**Common Anode w/individual external resistors**

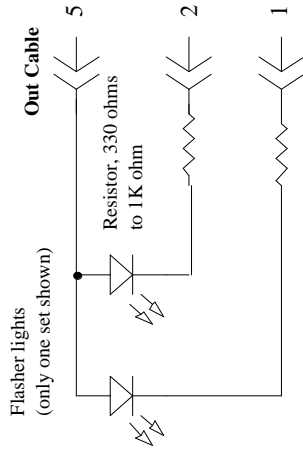

**Common Cathode**

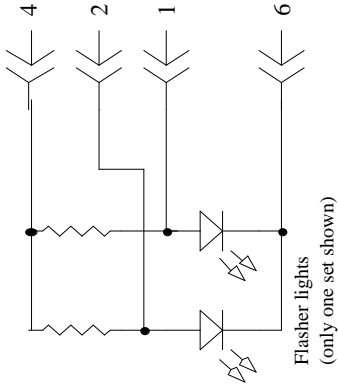





## WARRANTY INFORMATION

TDP & Associates guarantees the FlashMaster to be free of component and manufacturing defects for a period of one year after date of purchase. If a defect occurs return the product to TDP & Associates for service. TDP & Associates will repair or replace the FlashMaster at its discretion at no charge during the warranty period. This warranty excludes damage due to abuse, such as but not limited to failure to properly install the unit, applying excessive input voltage to the unit or failure to provide protection against input over current with a fuse or circuit breaker.

TDP & Associates will make non-warranty repairs to the FlashMaster at reasonable and fair rates.

All warranties on this product are limited to refund of purchase price or repair or replacement of this product at the sole discretion of TDP & Associates.

In the event that this product is not installed or used in accordance with the manufacturer's specifications any and all warranties either expressed or implied are void. Except for what is expressly stated in this section there are no warranties, express or implied, including but not limited to any warranties of merchantability or fitness for a particular application.

TDP & Associates, Inc. reserves the right to make changes to this product's design or specifications, and/or to make improvements to this product, at any time, without obligating TDP & Associates to install these changes, additions or improvements on previously manufactured products.

## CONTACT INFORMATION

TDP & Associates, Inc.

4 Jones Drive  
Garnet Valley, Pa. 19060  
(610) 358-0460

[www.trainspeed.com](http://www.trainspeed.com)

Email:

[sales@trainspeed.com](mailto:sales@trainspeed.com)

©2006, TDP & Associates, Inc.

Ver. 1.2